

TC Sensors

series 52201, 52401, 52501



Industry leading sensor with longest service intervals and lowest maintenance costs

Applications

In-line and package analysis

Dissolved and gaseous applications

Beverage production, power –steam and pharmaceutical industries

This thermal conductivity sensor is ideal for high-precision measurements under harsh conditions. The measurement range varies from trace to saturation level. Its concept and precise mechanical assembly ensure an optimal performance, a life cycle of about 8 years and low maintenance costs.

Benefits

- Measurement gases in both dissolved and gaseous phase
- CO₂, H₂ or N₂ concentrations are measured continuously
- Very low detection limits in dissolved and gaseous applications
- Low maintenance costs: one single annual maintenance is necessary
- The presence of other gases in the environment does not affect the measurements
- Fast response time +/- 30 sec.
- Easy air calibration process
- Stainless steel construction: ideal for harsh plant conditions and high pressures
- Resistance to high temperature and cleaning in place (CIP)

< 0.1 ppb detection limits

Very fast response time

Low maintenance costs

Easy air calibration process



Dextens SA
Ch.des Aulx 18 – 1228 Plan-les-Ouates - Switzerland
Phone: ++41 22 884 83 06 – Fax : ++41 22 794 66 65
E-mail : info@dextens.ch www.dextens.ch

Dextens

TC Sensors

series 52201, 52401, 52501

Principle

This thermal conductivity sensor is designed to continuously measure Carbon dioxide (CO₂), Nitrogen (N₂) or Hydrogen (H₂). Measurements are possible in dissolved or gaseous applications. The sensor operates on the following principle: the gas to measure diffuses from the sample into a micro volume contained in the sensor through a semi-permeable membrane, and comes into contact with a gas thermal conductivity detector. The temperature and the change in thermal conductivity induced by the presence of the gas is measured.

The duration of a single measurement is too short to get a reliable measure: successive measurements are made, which induce each time a conductivity curve. The average slope of each measurement curve determines the average conductivity, which gives the gas concentration of the sample. To perform the successive measurements, it is necessary to purge the gas enclosed in the micro-volume (every 10 seconds). This purge is done by injecting a purge gas, which is different from the sample to be measured (for instance N₂ for a CO₂ measurement). A purge valve controlled by an electronic card drives this process. After each purge, the gas to be measured diffuses again through the membrane into the sensor and a new measurement is performed.

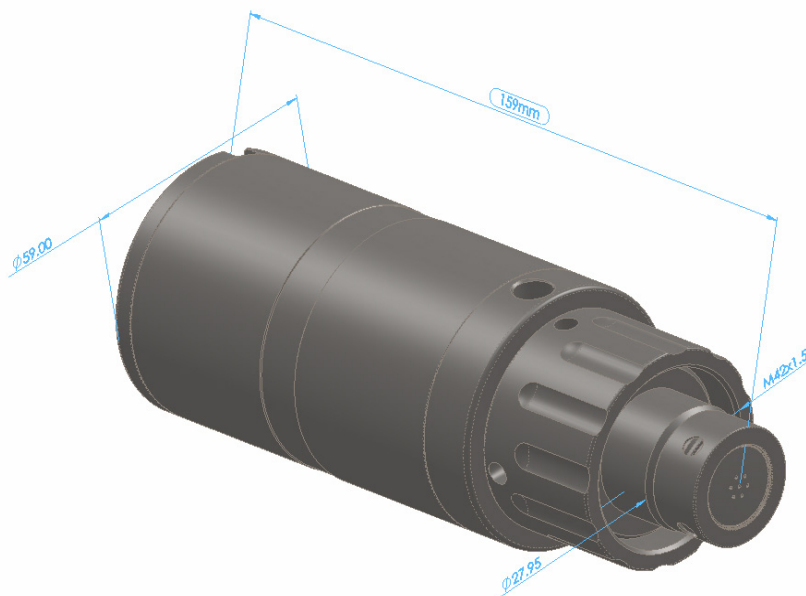

Technical Specifications

Sensor Model	CO ₂	H ₂		N ₂
Sensor serial number	52401	52201	52201	52501
Membrane model number	82956	82956	82952	82956
Measurement range at 25°C	0-15 g/kg 0-10 bar	0-2 ppm 0-1.5 bar	0-10 ppm 0-12 bar	0-350 ppm 0-20 bar
Linear flow rate	50 cm/sec	N/A	N/A	150 cm/sec
Accuracy	1% of the measured value or lowest value whichever is greater			
Temperature compensation	0°C to + 50°C / 32°F to 113°F			
Temperature range	CIP or SIP resistant up to 120°C / 248°F			
Pressure range	0 – 20 bars			
Cycle time	20 sec			
Recommended purge gas	N ₂ or air	N ₂ or air	N ₂ or air	CO ₂ or air
Weight	0.6 kg			
Enclosure protection	IP65			
Material in contact with sample	ANSI 316L, PFA or Tefzel			
Sensor cable	3m standard length / optional extension up to 1000 m			

Dextens SA

Ch.des Aulx 18 – 1228 Plan-les-Ouates - Switzerland

Phone: ++41 22 884 83 06 – Fax : ++41 22 794 66 65

E-mail : info@dextens.ch

www.dextens.ch

Dextens